

PowerStacker® Conveyor

Stockpile...Relocate...Repeat...Endure

Guaranteed Durability

Pound for pound and dollar for dollar, you can't find another brand that will last longer.



Clear-Cut Operation

Control folding, raising and radial travel action from central control panel or wireless remote.



Local

.....
Dealer
Support

Fastest Changeover



Patented FD Axle allows the world's quickest transition from road travel to working mode.

More Than

400

.....
Built To
Date



5-year

.....
Structural
Warranty

Maintenance Defense



Patented power fold system protects hydraulic cylinders from contaminants during operation.

First-Class Service

We have a fundamental belief in maintaining long-term relationships with our customers.

20,000

.....
Unique
Combinations



Featured Superior Brand Conveyor Accessory:

A heavyweight in its class, our beefy Exterra® Belt Cleaner is well known for its broad, full-figured shape...sized that way to outlast its competitors.



Jamieson Equipment Company
www.jamiesonequipment.com
toll free 800.875.0280

Stockpile Dimensions

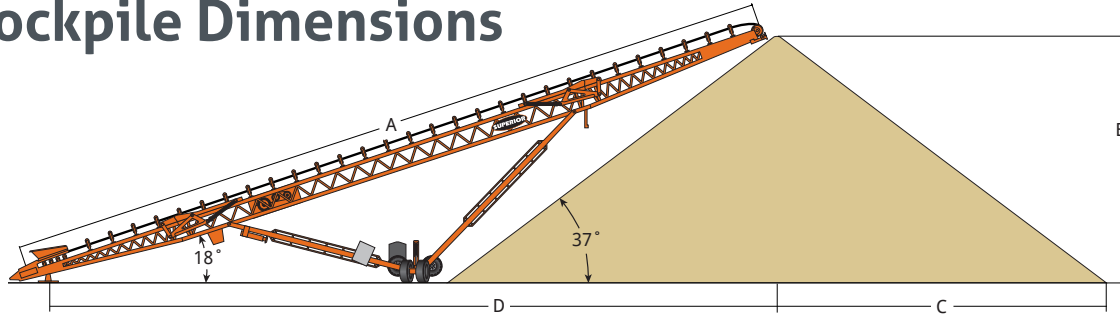

| Conveyor Length | A | 95' | 110' | 125' | 150' |
|--------------------------------|---|--------|---------|---------|---------|
| Stockpile Height | B | 31' 0" | 35' 6" | 39' 5" | 47' 6" |
| Radius of Pile | C | 41' 1" | 47' 1" | 52' 5" | 63' 0" |
| Anchor Pivot to Center of Pile | D | 91' 0" | 105' 6" | 119' 0" | 144' 0" |

Operating Dimensions

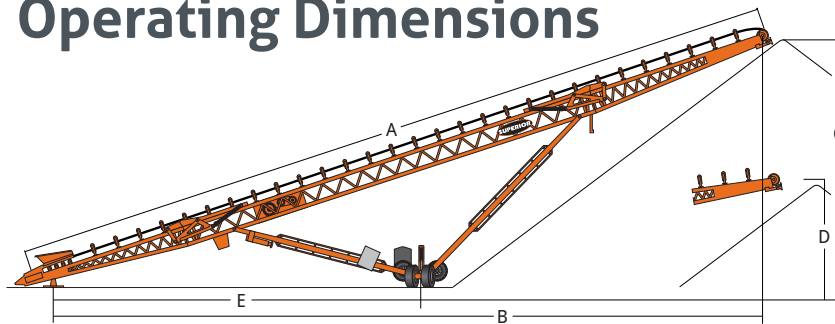

| Conveyor Length | A | 95' | 110' | 125' | 150' |
|------------------------------------|---|--------|---------|---------|---------|
| Conveyor Ground Length | B | 88' 4" | 102' 0" | 116' 1" | 140' 4" |
| Raised Height to Center of Pulley | C | 32' 3" | 36' 4" | 41' 4" | 48' 0" |
| Lowered Height to Center of Pulley | D | 13' 8" | 17' 2" | 17' 7" | 15' 2" |
| Anchor Pivot to Center of Axle | E | 47' 7" | 56' 3" | 59' 11" | 79' 2" |

Transport Dimensions

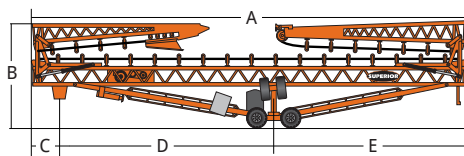

| Conveyor Length | | 95' | 110' | 125' | 150' |
|--------------------------|---|---------|--------|--------|---------|
| Travel Length | A | 78' 7" | 60' 9" | 70' 9" | 80' 6" |
| Travel Height | B | 13' 6" | 14' 1" | 14' 0" | 13' 10" |
| Tail to Kingpin | C | 5' 1" | 6' 0" | 6' 0" | 5' 9" |
| Kingpin to Axle | D | 50' 11" | 29' 2" | 33' 6" | 49' 6" |
| Axle to Head | E | 22' 8" | 25' 8" | 31' 3" | 25' 3" |
| FD Axle Size | - | FD15 | FD20 | FD40 | FD50 |
| Weight at Axle (lbs.) | - | 17,750 | 19,940 | 33,000 | 34,200 |
| Weight at Kingpin (lbs.) | - | 4,000 | 3,060 | 3,500 | 10,200 |